

18" Square Frame with Four 9" Square "Wave" Anti-Entrapment Suction Outlet Covers and Vented Riser Rings

VGB Series

The AquaStar line of suction outlet covers, compliant with the new Virginia Graeme-Baker Pool and Spa Safety Act (ANSI/APSP 16-2011 And NSF 50-2008)

Features

For single or multiple drain use (see installation instructions)

Single - 6" sump depth
Floor/wall: 628 GPM at 1.1 fps

176.8 square inch opening

Trademarked VGB compliance button easily identifies VGB 2008 compliant cover from on deck and underwater

#316 stainless steel screws

Manufactured from superior UV-resistant engineered polymers

See installation instructions for details and special requirements

All components (covers, frame, screws) meet or exceed ANSI/APSP 16-2011 AND NSF 50-2008 national standards and ASTM G154 UV testing exposure



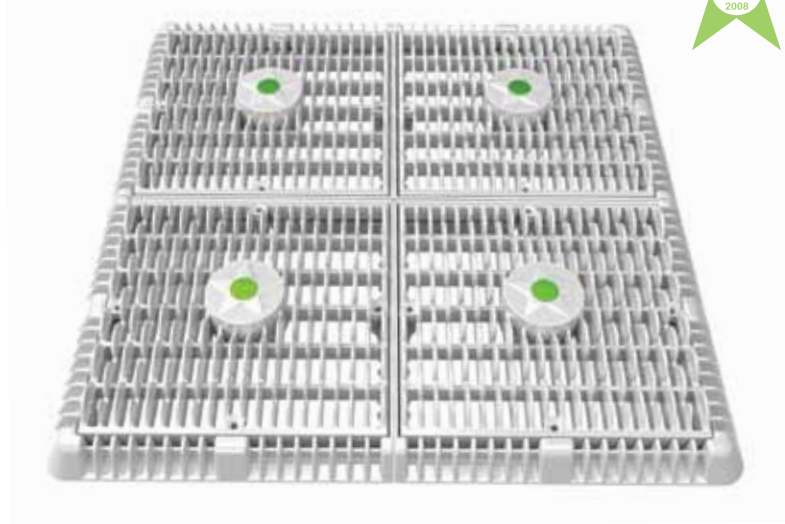

6 per case





Part # WAV18WRxxx

Grates fit: AquaStar (p/n 18xxx, pre-VGB "flat"); Pentair (#1 selling) with 3/4" deep existing window grid frame and 4x4 screw hole pattern

STANDARD COLORS

 101	 105
 102	 108
 103	

OPTIONAL COLORS

 104	 107
 106	

VGB 2008 Compliant

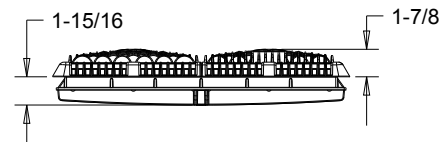
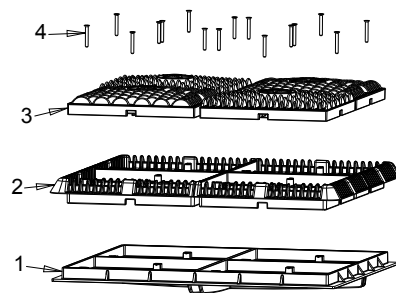
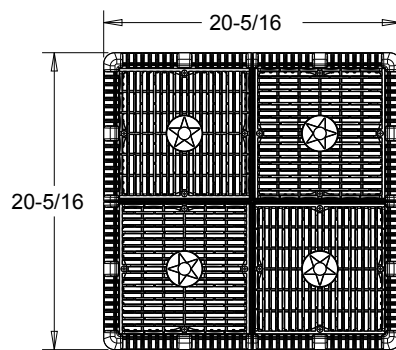

1. 18" square (4) 9"x9" frame, plastic
2. 18" vented riser ring
3. 9" x 9" wave square drain cover
4. #10 x 1-1/2" flat head phillips type-a screw, 316 ss