

VGB Series

The AquaStar line of suction outlet covers, compliant with the new Virginia Graeme-Baker Pool and Spa Safety Act (ANSI/APSP 16-2011 And NSF 50-2008)

Features

For single or multiple drain use (see installation instructions for plumbing, hydrostatic valve/drain pipe and single or multi-pump connections)
No additional sump required

Single –

Floor: 196 GPM at 2.3 fps

Wall: 88 GPM at 1.0 fps

Floor/Wall: 131 at 1.5 fps

27.9 square inch opening

Manufactured from superior UV-resistant engineered polymers

All components meet or exceed ANSI/APSP 16-2011 and NSF 50-2008 national standards and ASTM G154 UV testing exposure

Listed with IAPMO R&T

6 per case

The Unblockable![™]

NEW

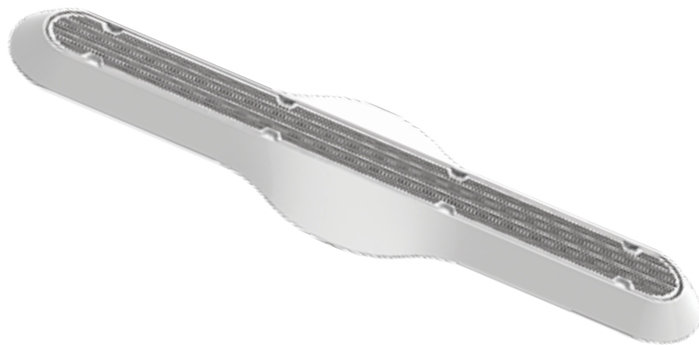

Notes: Propeller Sump must be permanently affixed to pool floor using epoxy and provided anchors to be considered unblockable

Part # 32PDxxx

No additional sump required

STANDARD COLORS

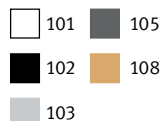

OPTIONAL COLORS

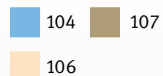

VGB 2008 Compliant

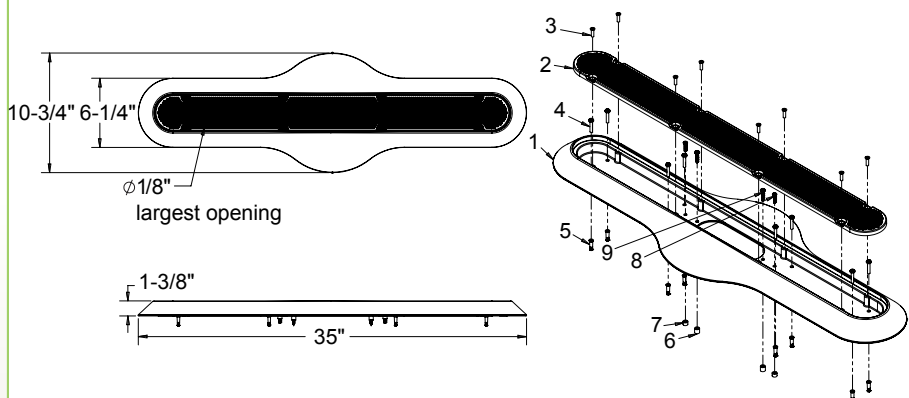

1. 32" propellor sump
2. 32" channel drain anti-entrainment suction outlet "pinhole" cover
3. #10 x 3/4" flat head phillips type-a screw, 316 ss
4. #10 x 1" pan head phillips screw, 316 ss
5. 1/4" concrete anchor

6. 3/8" bushing
7. 1/4" bushing
8. 8-32 x 3/4" lg. pan head phillips, 316 ss
9. #10 x 1" lg. pan head phillips, 316 ss
10. 10-24 x 7/8" pan head phillips, 316 ss
11. #8 x 3/4" pan head phillips, 316 ss
12. #8 x 1" pan head phillips, 316 ss