

32" Channel Drain Flat Grate Anti-Entrapment Suction Outlet Cover and Frame

VGB Series

The AquaStar line of suction outlet covers, compliant with the new Virginia Graeme-Baker Pool and Spa Safety Act (ANSI/APSP 16-2011 AND NSF 50-2008)

Features

- Requires a minimum 3" sump depth the entire length of cover
- For single or multiple drain use (see installation instructions)
- Single - 3" sump depth
- Floor: 316 GPM at 3.9 fps
- Wall: 208 GPM at 2.6 fps
- Floor/wall: 122 GPM at 1.5 fps
- 25.9 square inch opening
- Manufactured from superior UV-resistant engineered polymers
- All components meet or exceed ANSI/APSP 16-2011 AND NSF 50-2008 national standards and ASTM G154 UV testing exposure
- Includes disposable "dogbone" supports to retain shape during all phases of construction
- Listed with IAPMO R&T
- 12 per case

The Unblockable![™]

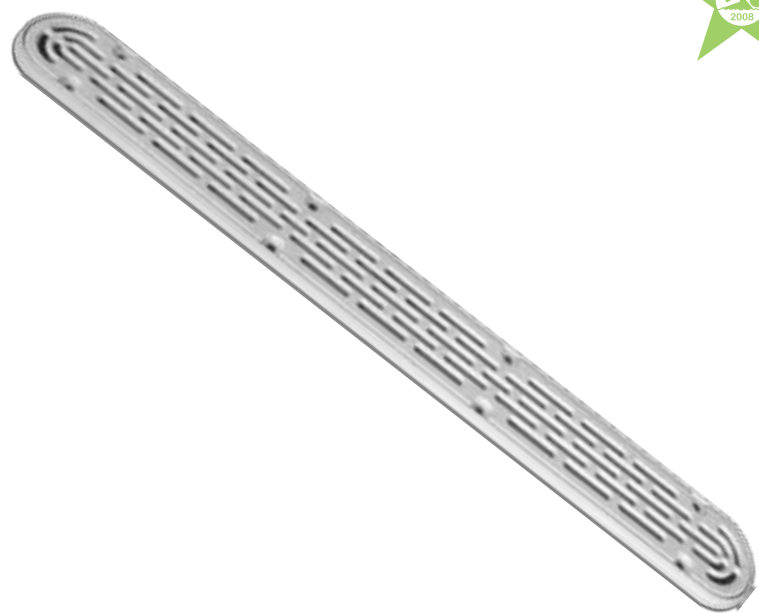

For field-fabricated sump (concrete pools)
Part # 32CDFLFRxxx

Two drains in one!

STANDARD COLORS

- 101 (White)
- 102 (Black)
- 103 (Grey)
- 105 (Dark Grey)
- 108 (Orange)

OPTIONAL COLORS

- 104 (Blue)
- 106 (Light Orange)
- 107 (Brown)

Also available cover only without sump/frame p/n 32CDFLNFxxx
40 per case

VGB 2008 Compliant

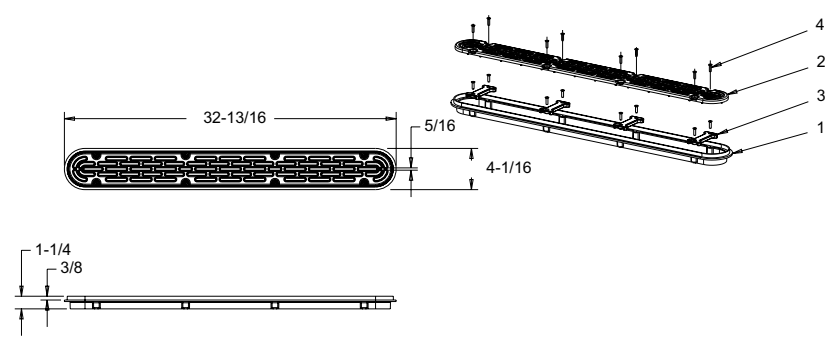

1. 32" channel drain, no sump, frame
2. 32" channel drain, cover, flat
3. 32" channel drain, frame support "dog bones", qty 4
4. #10 x 3/4" flat head phillips type-a screw, 316 ss, qty 16